

GRANZOW[®] INC.

HEAVY DUTY PERISTALTIC PUMPS

HOSE PUMPS WITH XXL ROLLERS

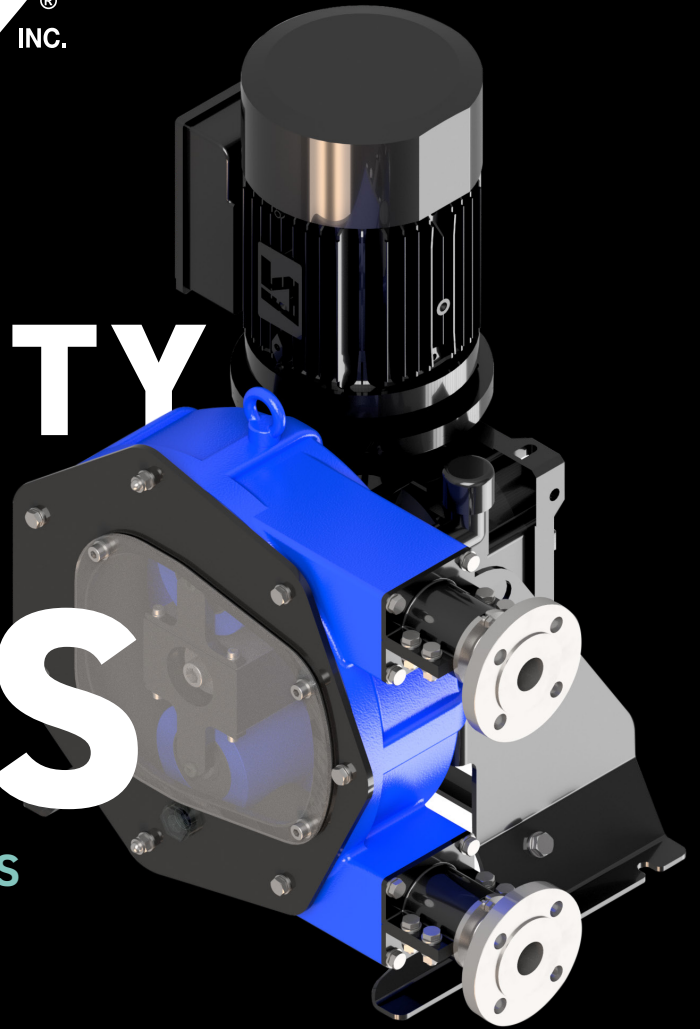

NEWEST PERISTALTIC TECHNOLOGY

- ▶ Maximum resistance to abrasion
- ▶ Unmatched suction capability
- ▶ Indefinite dry running
- ▶ No valves or mechanical seals
- ▶ Gentle and reversible pumping
- ▶ Full dosing control
- ▶ Industrial, chemical and food-grade versions
- ▶ Dosing accuracy of $\pm 1\%$



Assembled in the USA and shipped from Granzow's exclusive, dedicated pump production facility in North Carolina. Hundreds of configurations are stocked and ready to ship within 2-3 days!

704.845.2300 • granzow.com

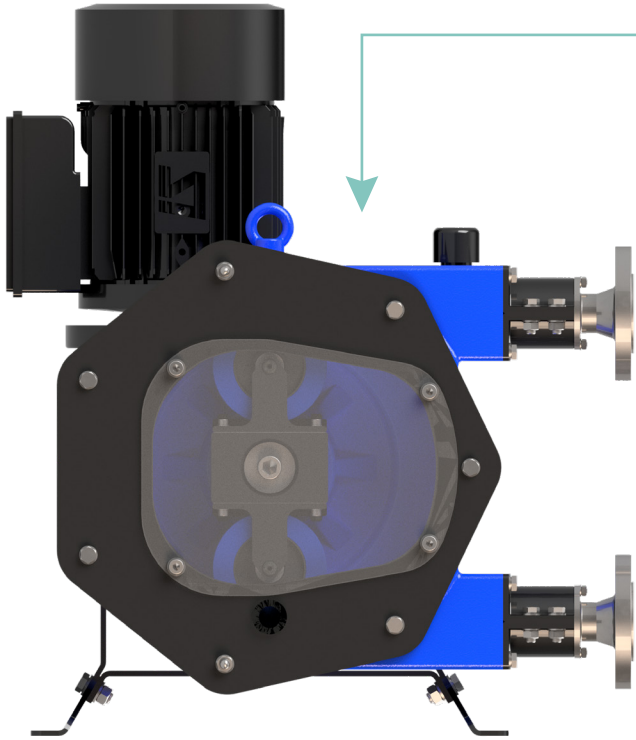

ADVANTAGES
over other pump technologies

VS

Hose pumps with shoes

- ▶ Up to 30% in energy savings
- ▶ Easier hose replacement
- ▶ Wider range of operation
- ▶ Lower starting torque

VS

Progressive cavity pumps

- ▶ Allows dry running
- ▶ No mechanical seals
- ▶ Easier pumping of corrosive products

VS

Diaphragm dosing pumps

- ▶ Easier to install
- ▶ Greater suction
- ▶ Better performance with solid and viscous media

VS

Air operated diaphragm pumps

- ▶ More efficient technology
- ▶ No valves (improves pumping of solids)

Examples of difficult media that can be transferred or dosed with ease

ABRASIVE

Lime milk, activated carbon, sludges and slurries

CORROSIVE

Sodium hypochlorite, ferric chloride and hydrochloric acid

VISCOUS

Water-based glues, greases, creams and resins

SENSITIVE

Latex, polymers, flocculants and food products

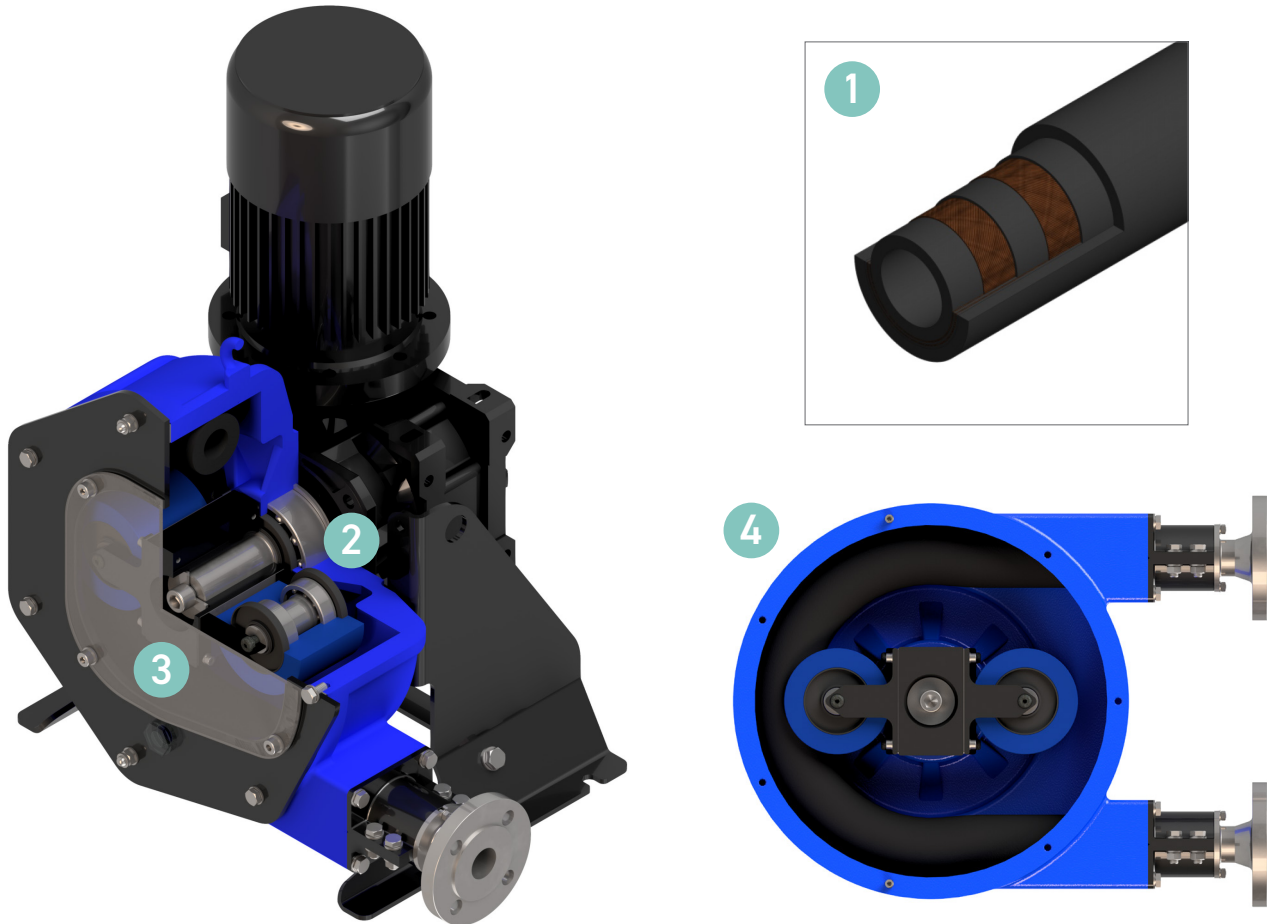

1 NEWEST PERISTALTIC HOSE TECHNOLOGY

High quality hose created with a unique manufacturing process: an extruded inner layer, high-density textile reinforcement and precision machined outer layer that ensures perfect compression and quick installation. Made from materials that are compatible with all types of media under various working conditions. Precise performance even in extreme temperatures or abrasive/corrosive conditions. **PROVIDES A LONGER HOSE LIFE WITH FAST, EASY REPLACEMENT.**

2 EXTREMELY HEAVY DUTY DESIGN

Integrated oversized bearings to withstand axial loads, large metal rollers with oversized bearings, a secure and reliable connection system and robust construction materials create the ideal pump for continuous working conditions. **OFFERS UNRIVALED PUMP LIFE AND SUPERIOR PERFORMANCE IN THE HARSHTEST CONDITIONS.**

3 EASY TO ASSEMBLE, OPERATE AND MAINTAIN

Fast and simple assembly, commissioning and maintenance. An innovative pump design allows for easy roller disassembly and quick hose replacement, resulting in less downtime. Maintenance-free pump with lubricated-for-life system requires only a small amount of lubricant, producing minimal waste. **DECREASES COST AND DOWNTIME.**

4 XXL ROLLER TECHNOLOGY

Excellent hose compression with no friction results in unmatched efficiency. Large rollers create a longer hose life, low energy consumption, minimal starting torque and a very wide frequency range. **GENERATES ENERGY SAVINGS AND A HIGHER NUMBER OF HOSE WORKING HOURS.**

FOOD-GRADE VERSION

A completely sanitary heavy duty hose pump that eases clean-in-place (CIP) processes

COMMON APPLICATIONS:

- ▶ Transferring viscous juices, sauces and syrups
- ▶ Pumping media with solid pieces in the mixture
- ▶ Dosing flavorings, colorings, additives and enzymes
- ▶ Pumping yeast and diatomaceous earth for brewing beer
- ▶ Transferring condiments, frostings and spreads
- ▶ Pumping casseroles, stews, and fillings

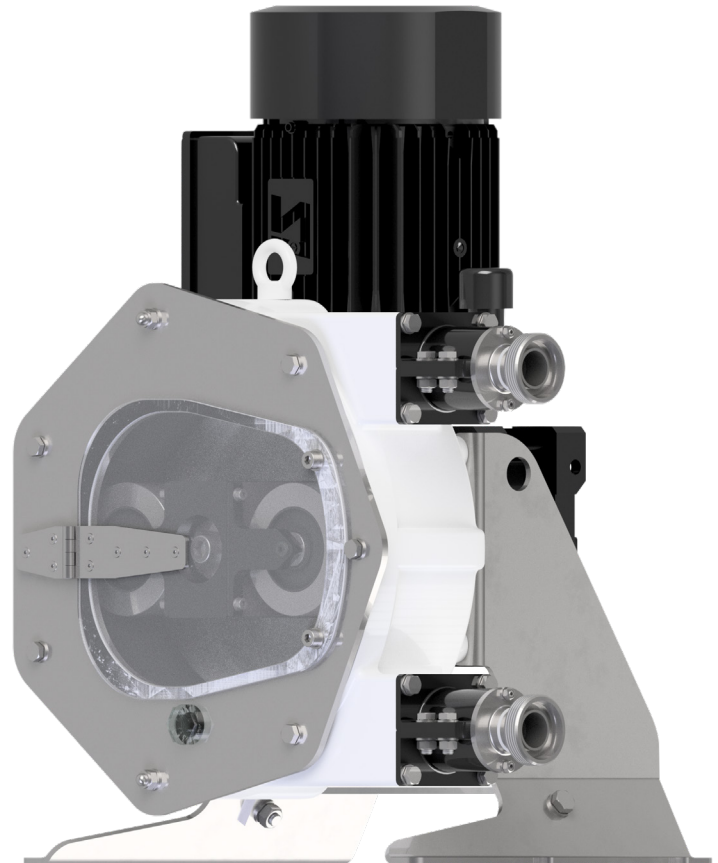

THIS VERSION INCLUDES:

- ▶ The newest peristaltic hose technology in FDA compliant, food-grade NBR
- ▶ Tri-clamp sanitary connections
- ▶ Hinged front cover and easy roller disassembly accelerate CIP processes
- ▶ Stainless steel base plate and cover
- ▶ Sanitary white painted housing

CHEMICAL VERSION

An anti-corrosive and unrivaled solution for dosing or transferring acids and other abrasive products

COMMON APPLICATIONS

- ▶ Pumping acids and other corrosive chemicals
- ▶ Gently pumping difficult products that form gas during transfer, such as sodium hypochlorite
- ▶ Dosing ferric chloride, hydrochloric acid, sulphuric acid and other fluids in chemical production
- ▶ Transferring calcium tartrate and highly abrasive crystals

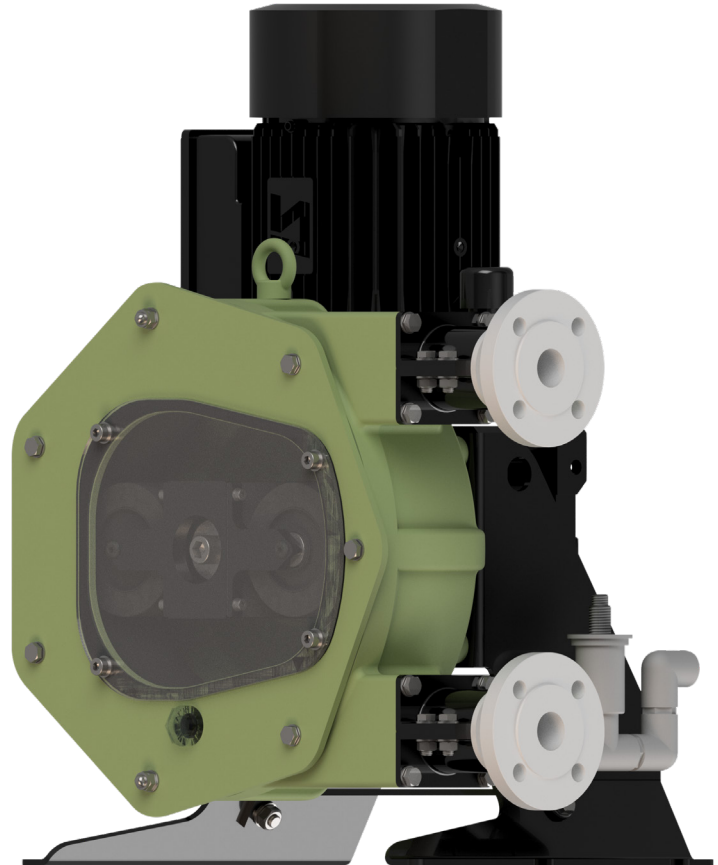

THIS VERSION INCLUDES:

- ▶ The newest peristaltic hose technology in NR, EPDM or Hypalon
- ▶ Tefzel coated front cover and housing
- ▶ Polypropylene or PVDF/PTFE connections
- ▶ Hose leakage sensor
- ▶ Pump and roller lip seals in EPDM
- ▶ Corrosion resistant rollers
- ▶ Drainage system